

Review the M-963-84 specification for Journal Box Lubricating Oil

Abstract –

- AAR M-963-84 is an All Year Journal Box Lubricating (JB) Oil specification which has last been revised in 1984
- D50E14 is a Traction Motor Support Bearing (TMSB) Oil specification for General Electric traction motor support bearings
- EMS 1002 is a Traction Motor Support Bearing (TMSB) Oil specification for EMD traction motor support bearings

Background –

- Many TMSB oils carry the D50E14 and EMS 1002 specifications for TMSBs, as well as the AAR M-963-84 specification for JBs. This allows for multiple uses in traction motors as well as journal boxes
- An oil carrying only AAR M-963-84 specification should only be used in Journal Box Lubrication and has led to at least one reported failure in a wick fed TMSB
- This led to a request for “modification” of the AAR M-963-84 specification

Conclusion –

- The M-963-84 JB Oil specification will be reviewed
- Compatibility testing is being conducted and results are discussed

Recommendation –

- Recommendations will be submitted to the AAR for consideration. Tune in this fall



Anju Singla, Dave Tuttle, Fred Girshick, Jerainne Heywood,
Shaji Koshy, Dennis McAndrew

Fuel, Lube, and Environmental Committee 2019



Review the M-963-84 specification for Journal Box Lubricating Oil

Freight Car Journal Box (JB)

AAR M-963 is required

“D50E14, EMS 1002, AAR M-963” oil is acceptable

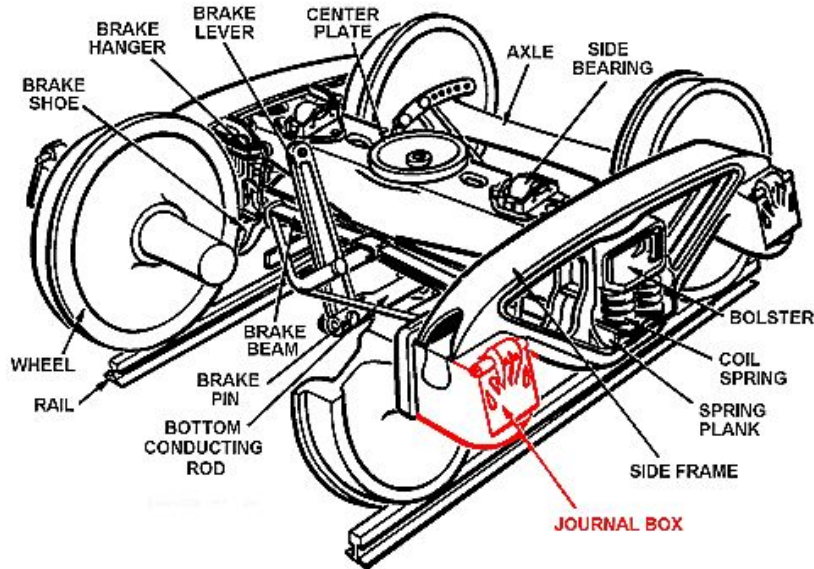

Traction Motor Support Bearing (TMSB)

D50E14 or EMS 1002 is required

“D50E14, EMS 1002, AAR M-963” oil is acceptable

“AAR M-963” (only) oil is NOT acceptable

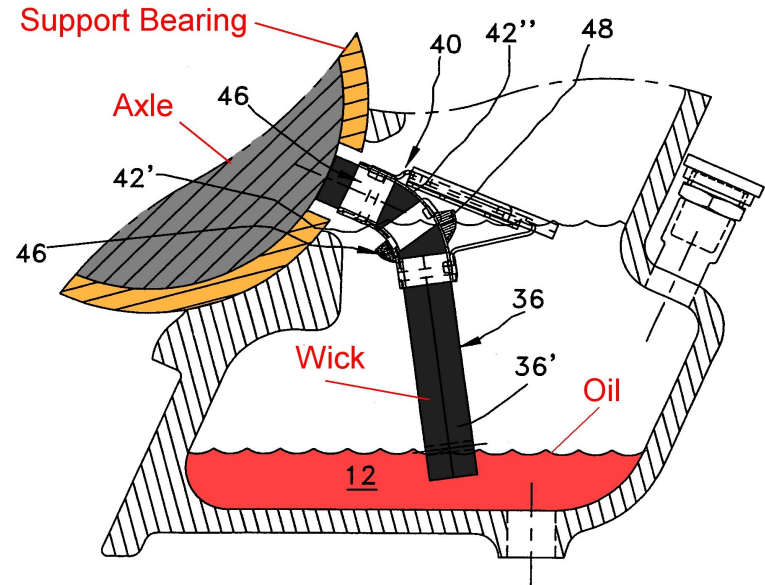

Anju Singla, Dave Tuttle, Fred Girshick, Jerainne Heywood,
Shaji Koshy, Dennis McAndrew

Fuel, Lube, and Environmental Committee 2019



Specialty Refining Solutions®